

SPECIFICATION SHEET

FIRE VESSEL WITH LARGE SURROUND

Index # 22, Rev-12
Page 1 of 2

MATERIAL OPTIONS:

This Fire can be sold as separate Components to make a unique design. Choose from materials below.

VESSEL MATERIAL: Hand Polished Cast Aluminium or Bronze

ENCLOSURE: Black Steel, Limestone, White Madre Perle or Black Granite.

FASCIA: Limestone, White Madre Perle or Black Granite.

CE APPROVAL:

Currently CE tested, approved and available for the following countries:

NG-I2H-G20-20mBar

UK, EIRE, AUSTRIA, DENMARK, SPAIN, FINLAND, ITALY, NORWAY, PORTUGAL & SWEDEN.

LPG-I3P(37)-G31-37mBar

UK, EIRE, SPAIN, BELGIUM & PORTUGAL.

DIMENSIONS:

Overall dimensions of surround: HEIGHT: 460mm x WIDTH: 1400mm x DEPTH: 40mm

Overall dimensions of fire: HEIGHT: 135mm x WIDTH: 360mm x DEPTH: 200mm

Dimensions of standard enclosure: HEIGHT: 330mm x WIDTH: 430mm x DEPTH: 360mm

Dimensions of required builder's opening:

HEIGHT: 695mm x WIDTH: 480mm x DEPTH: 330mm

FIRE VESSEL POWER RATING:

High and low flame settings (gas only):

Heat input high: NG - 4.5KW LPG - 5.2KW

Heat input low: NG - 2.4KW LPG - 2.9KW

OTHER TECHNICAL INFORMATION:

1. Rosal Limestone is a soft material which contains fossils, of which the quantity is not controllable. It is very absorbent and is easily marked by liquids and soot which is a natural by-product of a living flame.
2. Fire available in NG or LPG, see approvals above.
3. ODS (Oxygen Depletion System) to monitor oxygen levels in the room (gas only).
4. For use with chimneys or flues (unaided by mechanical extraction) with an internal free area no less than 127cm² - Class 2 x 3m length. Chimney/flue must be swept and tested prior to installation by a registered chimney sweep.
5. For air brick requirements please see air brick chart below in relation to high input settings.
6. Approximate running costs per hour on low (subject to your gas supplier tariff): NG - 2.7p LPG - 9.47p
7. Supplied as Hard Wire Remote Only [No Handset and Magic Eye]
8. Power Required for Remote - 240v, 3amp fused spur supply.
9. Gathers are optional depending upon installation requirements. If the standard gather is not to be used, the fire must be connected to the inglenook in accordance with CORGI and local regulations. The gather shown is for dimensional purposes only. The gather can be supplied as an optional extra. Please specify when placing your order.
10. Metal Casting
 - a. The Vessel is made from Cast Metal which is sand cast at a UK Foundry and then Hand Polished for over 15 Hours at the CVO Fire Factory. Pitting and Air Holes are a normal occurrence and are a part of the unique quality of such a hand made piece. All Bowls are inspected and given a full quality control check at the factory. Once the Bowl is installed it will be seen that the overall beauty and uniqueness of your CVO Fire outweighs what is a very minor feature of casting.

CVO reserve the right to amend and improve any of the specification sheets without prior notice.

All fires are living flames. Sooting can occur as a natural bi-product of a living flame and cannot be controlled or eliminated. Weathering and sooting of the enclosures is a natural and normal occurrence. This, understandably is more obvious on light coloured materials such as white stone and white powder coated steel.

Cast bronze and cast iron are hand sand cast and polished. Pitting and air holes are normal and a part of the unique quality of such a piece.



AIRBRICK CHART	
Input Energy:	No Airbrick Required
0-7KW	11cm ² free air
8-9KW	36cm ² free air
10-15	50cm ² free air
16-18KW	
KEY	
NG - NATURAL GAS	
SF - SOLID FUEL	
LPG - LIQUID PETROLEUM GAS	
ALL DIMENSIONS WITHIN +/- 2mm	

Spirit Fires Ltd, 4 Beaumont Square Durham Way South Aycliffe Industrial Park
Newton Aycliffe County Durham DL5 6SW
Tel: +44 (0) 1325 327 221 Fax: +(0)1325 327 292
Email info@cvo.co.uk

SPECIFICATION SHEET
FIRE VESSEL WITH LARGE SURROUND
 Index # 22, Rev-12
 Page 2 of 2

NOTE - The dimensions on this product is for a stone enclosure. The builders opening is not affected on a metal enclosure.

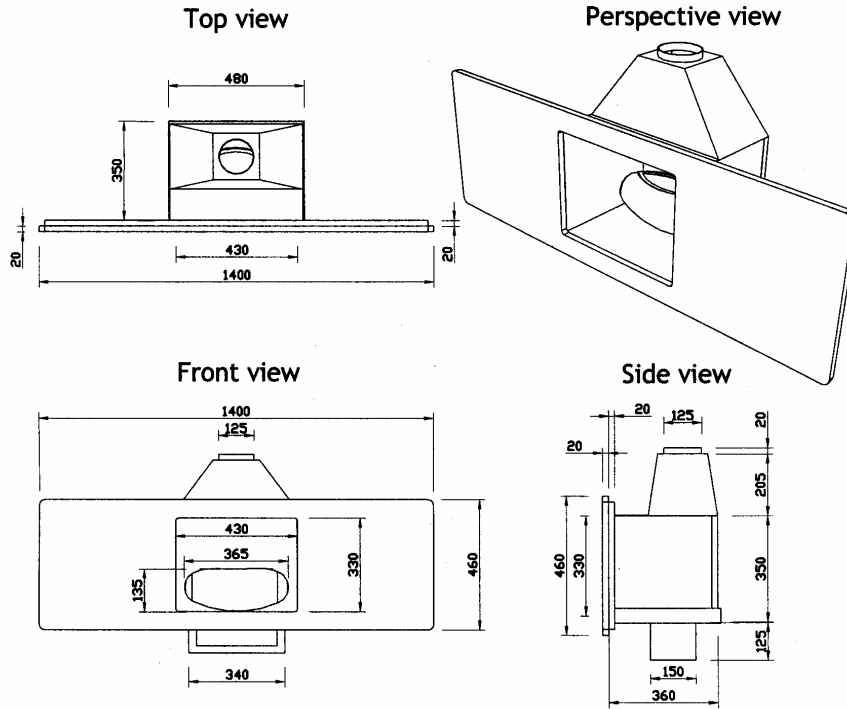

For the builders opening please allow room for adjustments, gas and electric supply. The enclosure sits 20mm out from the wall. Allow 50mm gap around the sides and the back of the unit.

CVO reserve the right to amend and improve any of the specification sheets without prior notice.

All fires are living flames. Sooting can occur as a natural bi-product of a living flame and cannot be controlled or eliminated. Weathering and sooting of the enclosures is a natural and normal occurrence. This, understandably is more obvious on light coloured materials such as white stone and white powder coated steel.

Cast bronze and cast iron are hand sand cast and polished. Pitting and air holes are normal and a part of the unique quality of such a piece.



AIRBRICK CHART	
Input Energy:	
0-7KW	No Airbrick Required
8-9KW	11cm ² free air
10-15	36cm ² free air
16-18KW	50cm ² free air
KEY	
NG	- NATURAL GAS
SF	- SOLID FUEL
LPG	- LIQUID PETROLEUM GAS
ALL DIMENSIONS WITHIN +/- 2mm	

Spirit Fires Ltd, 4 Beaumont Square Durham Way South Aycliffe Industrial Park
 Newton Aycliffe County Durham DL5 6SW
 Tel: +44 (0) 1325 327 221 Fax: +(0)1325 327 292
 Email info@cvo.co.uk