

Fire Wave™

Index Number: 73, Rev-10, [8-6-2011], Page 2 of 2

CVO Fire : 01325-301020 : www.cvo.co.uk : sales@cvo.co.uk



THE GATHER IS SUPPLIED WITH THIS FIRE AS STANDARD. THIS IS REQUIRED TO ENSURE THE FIRE OPERATES SAFELY.

NOTE THE BURNER VENTILATION REQUIREMENTS AS STATED IN TECHNICAL INFORMATION SECTION

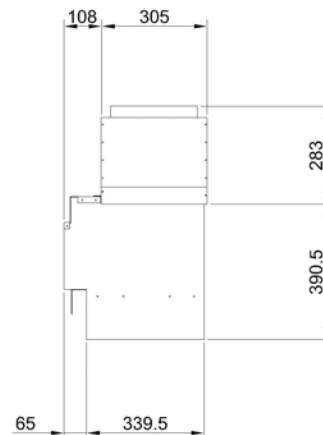
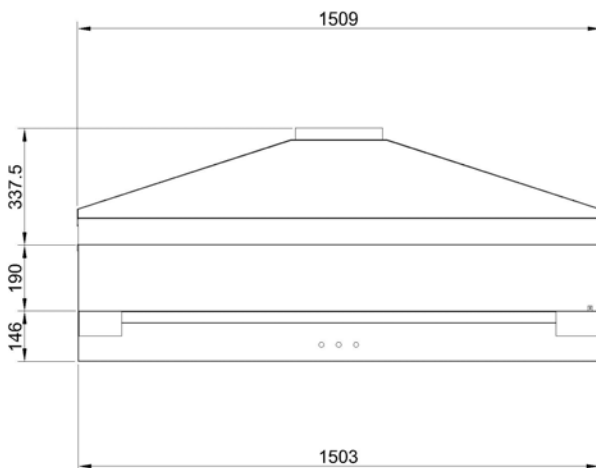
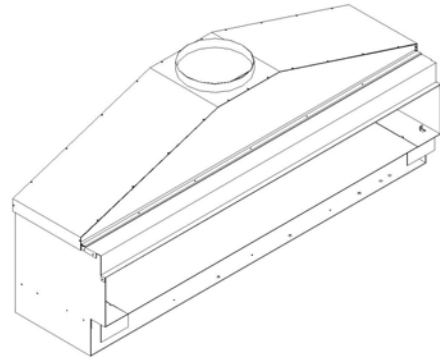
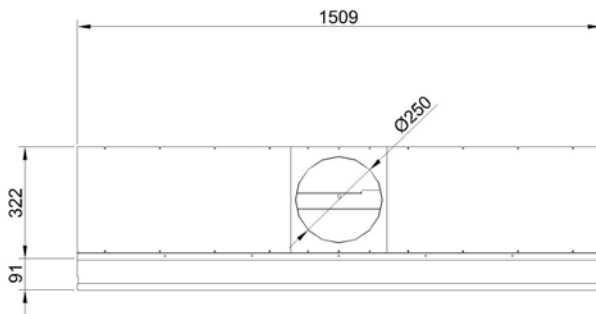

Before using this specification please read the specification in full to ensure the fireplace is correctly installed and supplied with an official install booklet. Spirit Fires Limited own the Spirit, CVO and Firevault Trademarks. Copying and distribution of these specifications is not permitted without the permission of Spirit Fires Ltd. All dimensions include a +/-2mm tolerance.

Spirit Fires Ltd, 4 Beaumont Square, Durham Way South, Newton Aycliffe, County Durham, DL5 6XN
Sales: +44 (0)1325-301020 Office: +44 (0) 1325 327 221 Fax: +(0)1325 327 292 Email: sales@cvo.co.uk Web: www.cvo.co.uk

SHOWROOM: CVO Fires can be seen live in our FIREVAULT showrooms based in the North and South of the UK. Visit www.firevault.co.uk or call 01325-301020 for full contact details, location maps and directions.