

## SPECIFICATION SHEET

### FRANCESCA "Hole in the Wall" GEL FIRE

A FLUELESS/CHIMNEYLESS FIRE

Page 1 of 2

Index Number : 83, Rev-1

#### FINISH OPTIONS:

- Enclosure in Black Satin Steel, With Brushed Stainless Steel Fascia.
- Other Finishes available upon request.
- Bespoke Sizes upon request.

#### DIMENSIONS:

Overall dimensions of the surround/fascia:

HEIGHT: 590mm x WIDTH: 990mm x DEPTH: 2mm (steel fascia).

Overall Dimensions of the enclosure opening:

HEIGHT: 390mm x WIDTH: 690mm x DEPTH: 250mm

#### OTHER TECHNICAL INFORMATION:

1. Hole in the Wall Design supplied with Gel Trough and CVO Ceramic Pebble Set.
2. 2.7Kw Heat Output
3. Usage approx 0.5lt/Hour (running times vary depending on Gel used).

#### IMPORTANT USER INSTRUCTIONS AND INFORMATION

- The Ceramics provided must not be placed inside the burner trough or in a position which will impede the flame. Failure to do this may result in harmful emissions being given off and entering the room.
- The Unit is supplied with 4 fixing holes on the rear face - 6mm diameter.
- The Enclosure lining which the unit will be placed inside must be fabricated from fire proof material inline with local and existing building regulations.
- The Gel trough requires a void below the unit and this must also be lined with heat proof material - see drawings on page 2. The cut out must be a minimum size of 450 (W) x 50 (D) x 100 (H).
- *User Guide:*
  - The gel to be used must be sold for this purpose. No other fuel must be used in the burner.
  - The gel is poured into the trough provided along the full length of the burner.
  - Ensure any spillages are wiped clean with a damp cloth and removed before lighting.
  - To light, simply touch the surface of the gel with a naked flame. We advise using a long lighter but matches can also be used. Ensure any used matches are disposed of and not left in the gel as this will cause smoke. After about 1 minute the flame will be at its full height.
  - To extinguish replace the lid provided ensuring that the flame is not touched.
  - Any gel remaining after use can be re-used but more gel should be added to re-light.
  - Allow some time for the gel to cool before re-filling. Do not re-fill when lit.
- Fire Gel can be purchased direct from the Spirit Fires website [www.spiritfires.co.uk](http://www.spiritfires.co.uk) and is sold at a competitive price.
- To service, wash out the trough every four burns to prevent the building up of residue.
- In locations where Children or Elderly people are present it is advisable to fit a dress guard or fire guard as this is an open fronted and open flamed appliance.
- If mounting the fire at a height lower than 300mm from the floor a hearth will be required.

CVO reserve the right to amend and improve any of the specification sheets without prior notice.

All fires are living flames. Sooting can occur as a natural bi-product of a living flame and cannot be controlled or eliminated. Weathering and sooting of the enclosures is a natural and normal occurrence. This, understandably is more obvious on light coloured materials such as white stone and white powder coated steel.

Cast bronze and cast iron are hand sand cast and polished. Pitting and air holes are normal and a part of the unique quality of such a piece.



Spirit Fires Ltd, 4 Beaumont Square Durham Way South Aycliffe Industrial Park  
Newton Aycliffe County Durham DL5 6SW  
Tel: +44 (0) 1325 327 221 Fax: + (0)1325 327 292  
Email [info@cvo.co.uk](mailto:info@cvo.co.uk)

[www.spiritfires.co.uk](http://www.spiritfires.co.uk)

Spirit Fires Incorporates the full CVO Fire range of Fires. For more details contact above or visit [www.cvo.co.uk](http://www.cvo.co.uk)  
**CVO FIRE** 

## SPECIFICATION SHEET

### FRANCESCA "Hole in the Wall" GEL FIRE

A FLUELESS/CHIMNEYLESS FIRE

Page 2 of 2

Index Number : 83, Rev-1

Top View

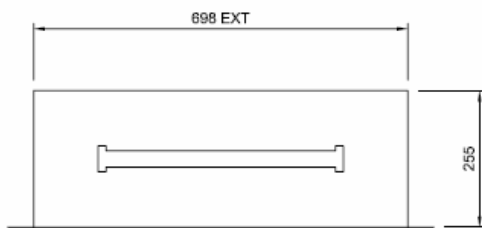

Perspective View

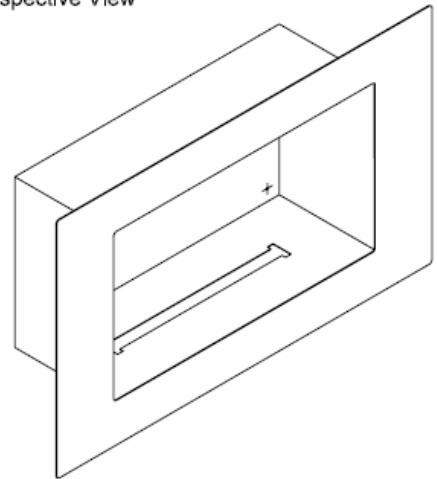

Front View

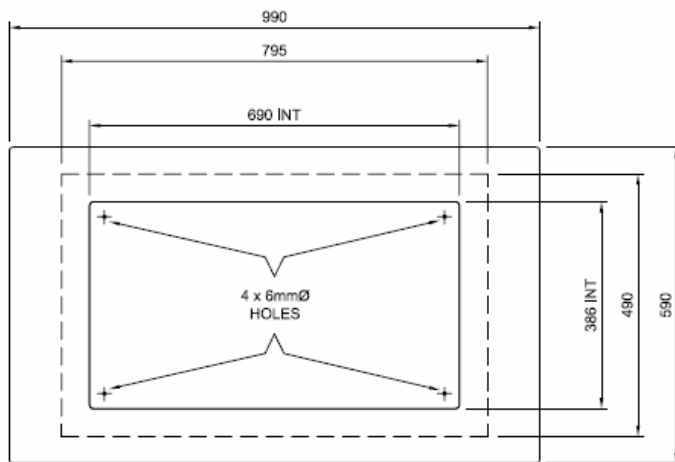

Side View

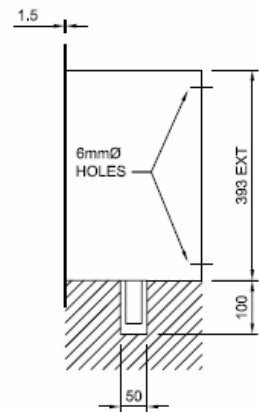

CVO reserve the right to amend and improve any of the specification sheets without prior notice.

All fires are living flames. Sooting can occur as a natural bi-product of a living flame and cannot be controlled or eliminated. Weathering and sooting of the enclosures is a natural and normal occurrence. This, understandably is more obvious on light coloured materials such as white stone and white powder coated steel.

Cast bronze and cast iron are hand sand cast and polished. Pitting and air holes are normal and a part of the unique quality of such a piece.



Spirit Fires Ltd, 4 Beaumont Square Durham Way South Aycliffe Industrial Park  
Newton Aycliffe County Durham DL5 6SW  
Tel: +44 (0) 1325 327 221 Fax: + (0)1325 327 292  
Email info@cvo.co.uk

www.spiritfires.co.uk

Spirit Fires Incorporates the full CVO Fire range of Fires. For more details contact above or visit [www.cvo.co.uk](http://www.cvo.co.uk)

**CVO FIRE** 